

Note: each time you are finished with a circuit we ask that you disconnect all wires, so that the next circuit you investigate starts with a “blank slate”.

Concepts of This Module

- Resistance
- Ohm’s Law
- Series and Parallel Circuits
- Electric Power



Course Concepts

Activity 1

Consider the circuit shown to the right using three of the supplied light bulbs labeled $6V\ 6W$. The label means the bulb is rated for 6 watts at 6 volts

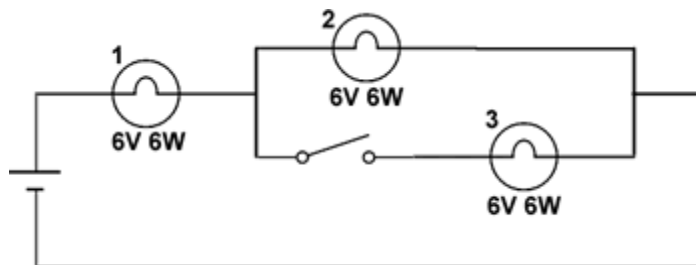

- Without doing any calculations, *predict* what will happen to the brightness/dimness of Bulb 1 when the switch is closed. Explain your prediction without equations.
- Wire the circuit and check your prediction. Was your prediction correct? If not, describe what happened.
- How does the brightness of Bulb 2 change when the switch is opened and closed?
- With the switch closed, how does the brightness of Bulbs 2 and 3 compare?

We will return to this circuit in Activity 11.



Expt

Activity 2

In Module 2 you used a $6V\ 6W$ light bulb and measured the voltage drop ΔV across it and the current I flowing through it in a circuit such as shown to the right. Repeat those measurements for each of the three supplied $6V\ 6W$ light bulbs. Are all the values exactly the same? Quantify the spread in values by assigning an uncertainty to the voltage drops and currents.

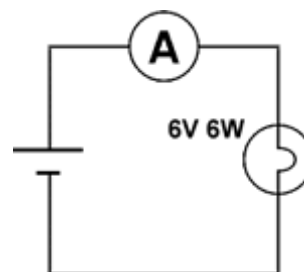

Course Concepts Activity 3

- A. The light bulb labeled $6V\ 1W$ is rated for 1 watt at 6 volts. Measure the current I and the voltage drop ΔV across it in the shown circuit. Compare the brightness and the values for the voltage and current to those of the $6V\ 6W$ light bulb.
- B. Can you combine the numbers from Part A and Activity 2 to give a single formula that gives the rated wattage for each bulb? What is the unit of the quantities that are combined in the formula to give the wattage?

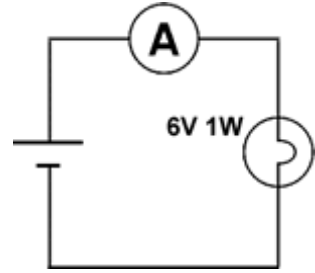

Course Concepts Activity 4

In **Electricity and Magnetism Module 2**, an analogy of current flowing in a wire was made to water flowing in a garden hose. A Flash animation of this analogy is available at <http://faraday.physics.utoronto.ca/IYearLab/Intros/DCI/Flash/WaterAnalogy.html>. We shall be extending that analogy in the next Activity. Open the animation and explore the two possible values of the *Voltage/Pressure* that are available.

- A. In the animation of the electric circuit, the movement of the negatively charged electrons in the conducting wire is shown. Is this in the same direction as the *conventional* current that you explored in Module 2?
- B. As discussed in Module 1, in the 1700's Benjamin Franklin and William Watson arbitrarily called the charge on a glass rod after being rubbed with silk *positive* and the charge on rubber after being rubbed with fur *negative*. If they had made the opposite choice, how would your answer to Part A change?

Course Concepts Activity 5

For a garden hose a pressure difference Δp generates the flow of the water. We shall give the symbol w to the volume of water per time passing a cross-section of the wire in m^3/s . The hose has a resistance R to the flow of the water and we can define the resistance as:

$$R \equiv \frac{\Delta p}{w} \quad (1)$$

This resistance is approximately constant for a given hose.

Similarly, a voltage difference ΔV causes the electric current I to flow in the wire, and the wire has a resistance R to the flow:

$$R \equiv \frac{\Delta V}{I} \quad (2)$$

Just as for the hose, for a given conductor the resistance is usually approximately constant. Equation 2 is called *Ohm's Law*. The unit of resistance is *volts / ampere*, which is called an *ohm* Ω . (Ω is the Greek letter *omega*.)

The circuit diagram symbol for a resistance is: 

- A. A hose of length L and area A is shown. How would you expect the resistance of the hose to the flow of water to depend on its length? How might the resistance depend on its area?

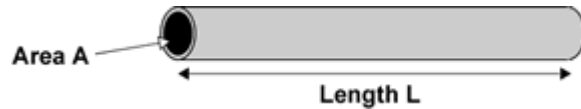

- B. A wire of length L and area A is shown. How would you expect the resistance of the wire to the flow of electric charge to depend on its length? How might the resistance depend on its area?

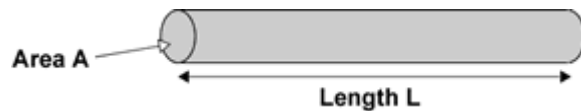

- C. A perfect ammeter and a perfect wire both have zero resistance. In Module 2 Activity 7 you measured a number of voltage differences for the circuit shown to the right. From that data, what is the actual resistance of the ammeter? Of the wires? Calculate the resistance of the $6V\ 6W$ and the $6V\ 1W$ light bulbs; you may already have the data for this calculation.

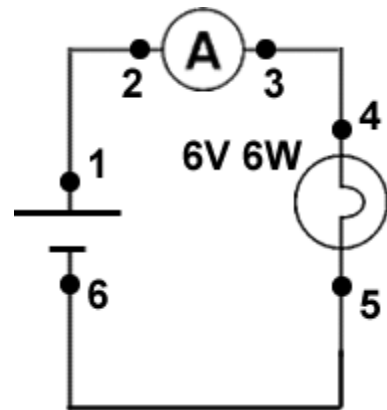

For the light bulb, you will need to know that as it heats up its, resistance changes. Thus when doing measurements of a light bulb in a circuit, be sure to give it a few seconds to reach equilibrium.

In terms of the resistances of the wires, ammeter, and light bulb we can represent the circuit as shown: in this representation the lines connecting the circuit elements have zero resistance.

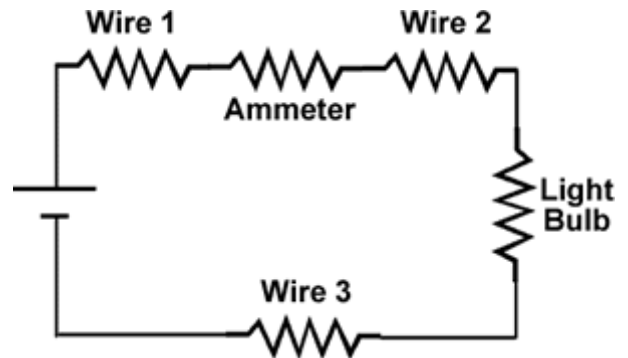

Course Concepts **Activity 6**

In Activity 5 we wrote Ohm's Law as:

$$R \equiv \frac{\Delta V}{I}$$

Here are two other ways of writing this Law. All three forms are mathematically equivalent.

$$\Delta V = IR$$

$$I = \frac{1}{R} \Delta V$$

Which of these three forms best expresses the relation between the current and the voltage?

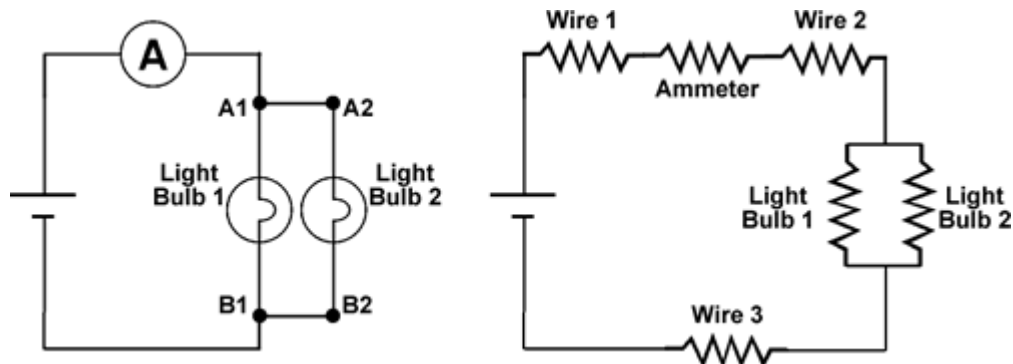

Course Concepts **Activity 7**

You are supplied with two short wires which we will assume are perfect and have zero resistance. The plastic cylinder of the banana sockets of the mount for the light bulbs can be unscrewed so that a wire can be inserted into a hole in the conductor. Use the two wires to connect two of the $6V$ $6W$ light bulbs together in parallel and place the combination in a circuit with an ammeter and the battery. On the left is a circuit diagram, and the diagram on the right represents the components as resistors.

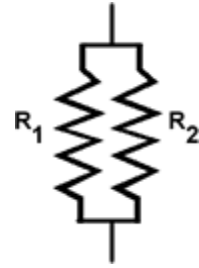

The current in the circuit may be over 1A. As discussed in Appendix 2 of the Electricity and Magnetism Module 2, the inputs to the ammeter should be connected to **10A COM** and **10A** sockets.

- A. The two short wires are the segments between points **A1** and **A2** and between **B1** and **B2**. When you measure the voltage across the two light bulbs, does it matter whether you connect the voltmeter across **A1** and **B1**, across **A2** and **B2**, across **A1** and **B2**, or across **A2** and **B1**? Why?
- B. Say the resistance of each light bulb is R . Without using equations but using the reasoning of Part B of Activity 5, predict the effective resistance R_{eff} of the two bulbs together in the circuit.
- C. Measure the effective resistance. Was your prediction correct?
- D. If two different resistors R_1 and R_2 are wired in a circuit in parallel, what is the effective resistance R_{eff} of the two? You may need to do a derivation to answer this question.



Course Concepts

Activity 8

Use one of the short wires to connect two of the $6V$ $6W$ light bulbs in series, and place the combination in a circuit with an ammeter and the battery, as shown.

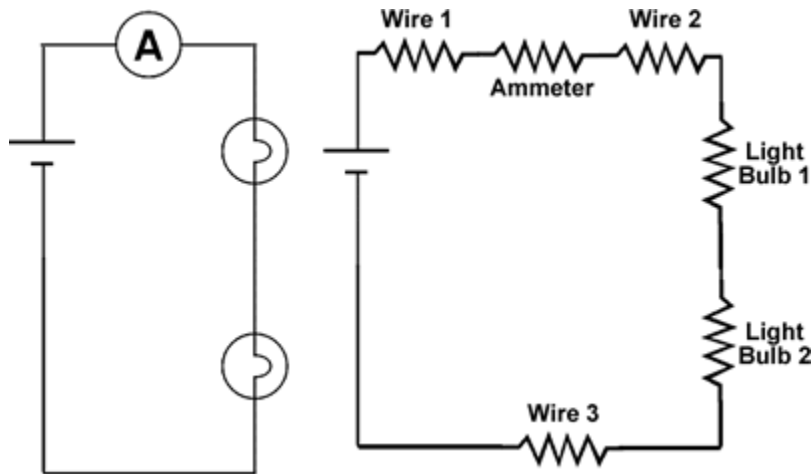

- A. How does the brightness of the light bulbs compare to their brightness in the parallel circuit of Activity 7?
- B. The brightness of the bulb is a function of the temperature of filament wire. Therefore, the resistance of each light bulb is different than the value you have been using. Measure the resistance of each individual light bulb when they are in the above circuit.
- C. If the resistance of each light bulb is R' , predict the effective resistance R'_{eff} of the two bulbs together in the circuit. You may find Activity 5 Part B useful in making your prediction.
- D. Check your prediction by measuring the resistance of the combination.
- E. If two different resistors R_1 and R_2 are wired in a circuit in series, what is the effective resistance R_{eff} of the two resistors? You may need to do a derivation to answer this question.



Course Concepts Activity 9

The diagram to the right has 6 different resistors that are connected by perfect wires. Describe how you might calculate the total effective resistance between points A and B. You may find it helpful to re-draw the diagram with the resistors and wires laid out in a more standard fashion. You will not need to write down any formulas to do this Activity, but just describe how to do the calculation.

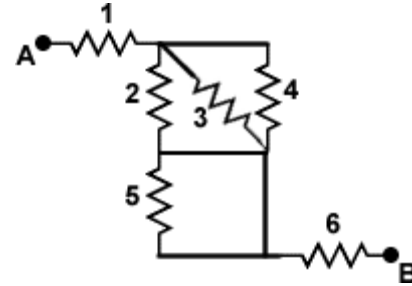

Course Concepts Activity 10

- In Activity 3 Part B you devised a formula for the wattage of the light bulbs. Modify the formula so that it involves only the voltage drop across the light bulb ΔV and its resistance R .
- Modify the formula so that it involves only the current flowing through the light bulb I , and its resistance R .

Course Concepts Activity 11

Assume that the change in resistance of a light bulb when it has a different brightness is negligible. Explain all the results for the brightness of the bulbs in Activity 1 using reasoning and/or expressions you have derived or learned in class.

Course Concepts Activity 12

- Recall that a “6V 6W” light bulb is rated to dissipate energy at a rate of 6 W when the potential difference across it is 6 V, and a “6V 1W” light bulb dissipates 1 W when the potential difference across it is 6 V. If a 6V 6W light bulb and a 6V 1W one are wired in series, as shown, predict which light bulb will be brighter.
- Wire the circuit and check your prediction. Were you correct? Explain.

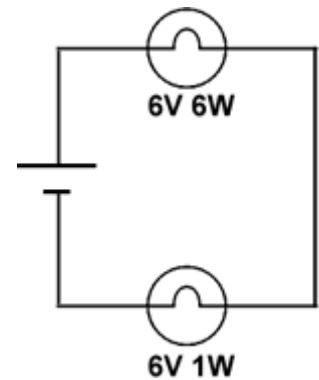

Course Concepts **Activity 13**

So far we have been treating the battery as perfect: it delivers a constant voltage in all circuits. Real batteries have a non-zero resistance, and we can represent the internal resistance r of the battery as shown. Now the battery symbol represents a perfect battery in series with the internal resistance of the real battery. Call the voltage of the perfect battery ε .¹

Describe how the voltage delivered by a real battery ΔV_{real} varies with the current I being drawn from it.

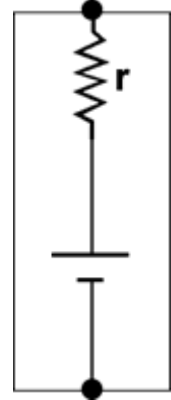

Course Concepts **Activity 14**

The earth contains minerals and moisture, which means that it is usually a good conductor of electricity. Therefore, it is possible to wire a light bulb using the earth as the return path for the current: in the figure two metal rods have been stuck into the ground and connected to the circuit as shown.

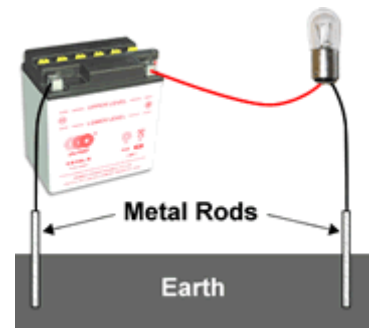

The symbol for a connection to ground is: 

Therefore we can represent the above circuit as shown to the right.

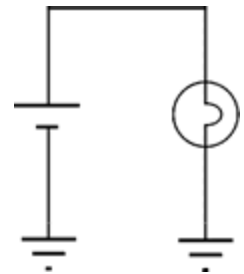

- A. The resistance of your arm from your palm to your shoulder is about 150Ω .
Estimate the resistance of your body from your palm to the soles of your feet.

¹ ε is sometimes called the *emf*.

- B. An electric fence consists of a single wire connected to one terminal of a voltage source; the other terminal of the voltage source is connected to ground. If the voltage ΔV is 120 volts and you touch the fence with your hand while standing on the ground in your bare feet, what is the number of watts your body will absorb while in contact with the wire?

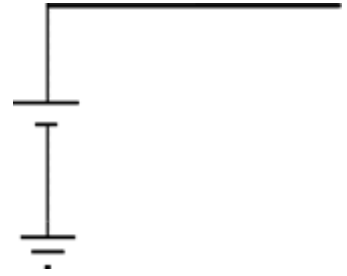

This Guide was written in November 2007 by David M. Harrison, Dept. of Physics, Univ. of Toronto.

The cartoon of the person touching an electric fence is from the Glasgow Digital Library:
<http://gdl.cdlr.strath.ac.uk/hewwat/hewwat0206.htm>

Last revision: March 26, 2011.